

Instruction Manual

EESIFLO EASZ-12 Doppler Flow Switch

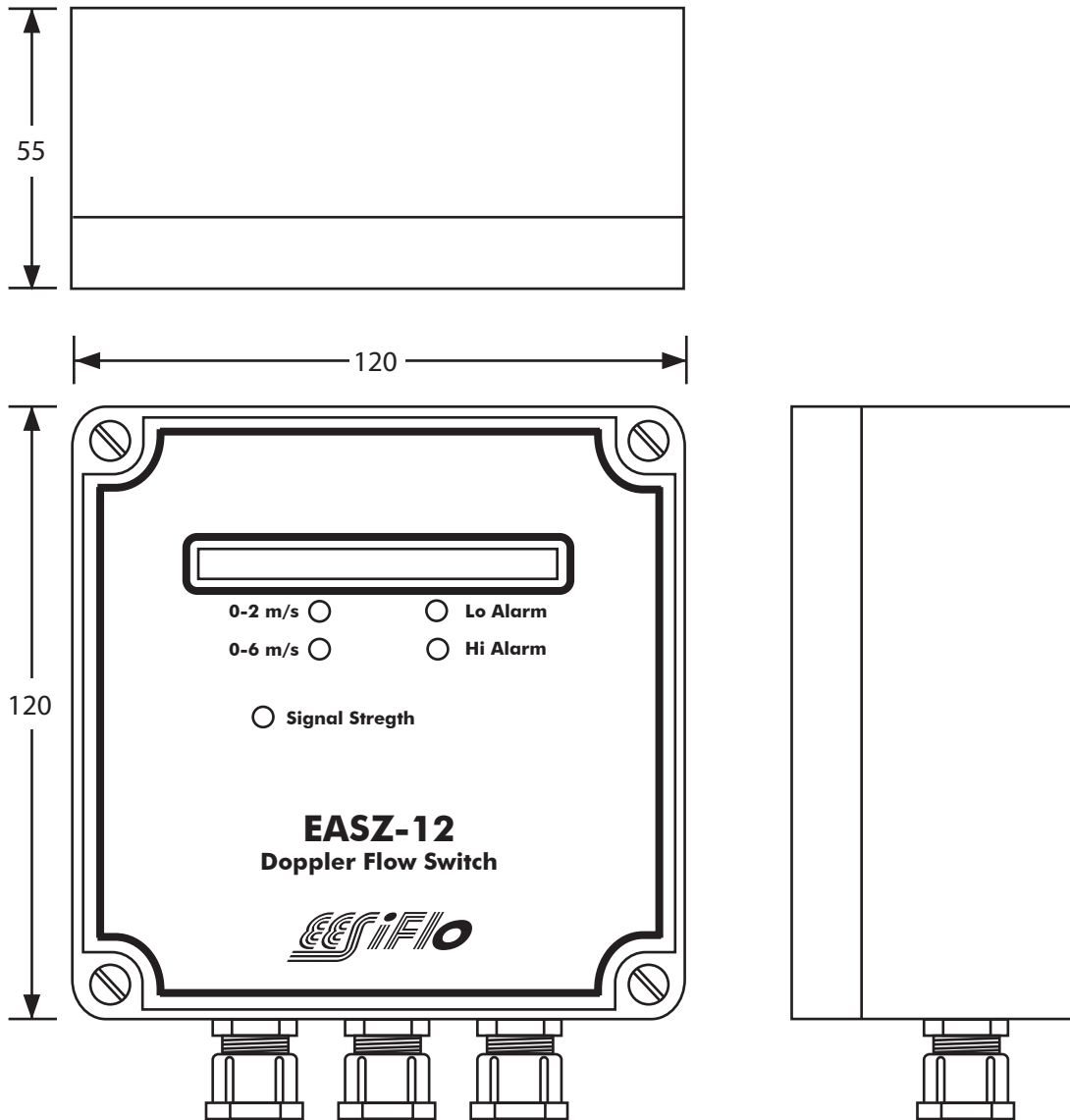

Doppler Flow Switch - EASZ-12

Introduction

The **EESIFLO EASZ-12 doppler Flow Switch** measures the velocity of fluids in pipelines using a totally non-intrusive principle.

It is intended for use with sewage, pulps, mining slurries, and other fluids which contain in excess of 0,1% suspended solids or bubbles. The particle size for successful operation must be greater than 100 microns.

The EASZ-12 enclosure is rated IP68. The flow switch includes a relay with adjustable high and low set point controls, plus delay-on and delay-off adjustable timers. The EASZ-12 requires 24Vdc, 115 or 230Vac power supply.

Two selectable flow ranges of 0 – 2 m/s, or 0 – 6 m/s are available, and the flow rate is displayed on a bar graph indicator.

Connections and Adjustments

Removal of the flow switch cover will reveal the plug-in connections and various adjustments, detailed as follows :-

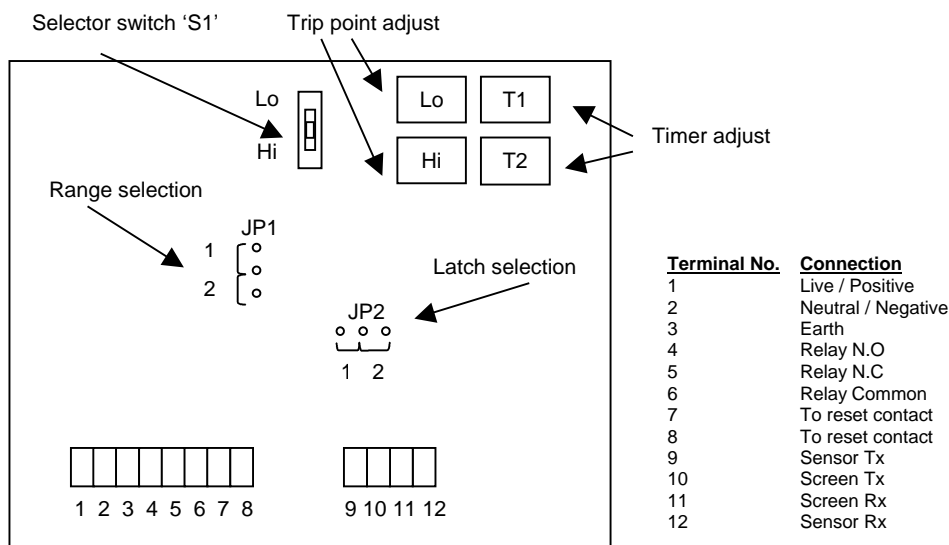

Figure 1

Connections

- Sensor** : Connect the sensor to the 4-way terminal plug as indicated in Figure 1 Terminal No's 9 to 12.
- Power Input** : Check that the operating voltage of the flow switch is correct, (i.e. 24Vdc, 115Vac or 230Vac) before connecting the supply.
- Relay** : The relay has a changeover contact, which can be used for pump control, or simply to initiate an alarm condition. The single control relay will operate when the flow measured is outside the high or low trip settings and can be configured to operate with or without "latch". With the latch selection jumper in position "2" (refer to JP2) the EASZ-12 is configured for simple alarm operation and the relay will be energised when an alarm condition occurs.
- Reset** : With the latch selection jumper in position "1" (refer to JP2) the control relay will latch when an alarm condition occurs, giving a failsafe mode. In this mode the relay is energised under normal conditions.
If used for pump protection it is either necessary to power the EASZ-12 from the pump control circuit, ensuring that power is initially applied when the pump is started or to initiate the delay-on timer with the reset contact. This allows timer T2 to override the low flow alarm until the flow is established.
i.e. on power up/reset the relay will energise ignoring an alarm condition if it exists until the timer T2 times out. Under operating conditions, if an alarm condition occurs, the relay will de-energise and latch.

Adjustments

Range Selection : (refer JP1)

Range 1 (0 – 2 m/s) :- Jumper in position “1”

Range 2 (0 – 6 m/s) :- Jumper in position “2”

Setting Low Flow Trip Point :

Move slide switch “S1” to “Lo” position. Adjust the low trip potentiometer until the bar graph displays the required alarm setting as a percentage of the flow range selected.

Example : Range 1 (0 – 2 m/s)
Bar graph display – 50%
Trip point setting – 1,0 m/s

Setting High Flow Trip Point

Move slide switch “S1” to “Hi” position and adjust high trip potentiometer to display the required alarm setting.

NB Return slide switch to centre position for normal operation.

Delay-Off Timer T1 :

Under normal operating conditions the flow may fluctuate beyond the high or low trip settings momentarily. The adjustable 0 – 60 sec. timer is adjusted with potentiometer “T1”. Turn clockwise to increase the delay before the relay operates.

Delay-On Timer T2 :

If the flow switch is used for pump control it is necessary to over-ride the trip settings during start-up, until the flow is established.

The adjustable 0 – 60 sec. timer is adjusted with potentiometer “T2”. Turn clockwise to increase the delay before the relay operates.

Mounting The Transducer

- a) Select a location for mounting the sensor at a point where the flow profile is fully developed. Generally the principle of 10 pipe diameters of straight pipe upstream, and 5 pipe diameters downstream will suffice, but should valves or bends exist upstream of the sensor, the amount of straight pipe immediately upstream will need to be increased.
- b) Ensure that the sensor is mounted as far as possible from potential noise sources, such as pumps, control valves etc. and mount the sensor at approximately 3/9 o'clock on the pipe (if horizontal) to avoid errors due to air pockets on top, or sediment at the bottom of the pipe.
- c) Either vertical or horizontal pipe runs are acceptable for sensor mounting.
- d) Before attaching the transducer head to the pipe surface, an area slightly larger than the flat surface of the transducer must be cleaned to bare metal. (A small amount of pipe pitting, even with spots of paint or rust, will not cause problems).
- e) The transducer must be mounted accurately, parallel to the pipe axis, for correct performance, and transducer to pipe contact should be along the centre line of the transducer head.
- f) Bonding to the pipe is achieved with silicone coupling compound. Be sure to fill in any air gaps that may remain at the pipe transducer interface with additional compound.

A pipe clamp kit is included with the flow switch. It includes silicone coupling compound, a Neoprene rubber pad, and four polyamide 12 straps for pipe diameters up to 300 mm. In applications with excessive vibration it is recommended that the Neoprene rubber pad is inserted between the pipe and the transducer. Coupling compound must be applied to both sides of the pad.

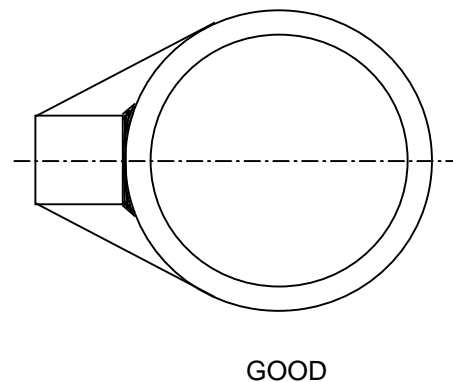

Mounting the Switch

The EASZ-12 electronics is housed in a water resistant housing, which should be mounted in a location where the ambient temperature is within the range stated in the specifications i.e. -10°C to 50°C.

Trouble Shooting

Relay Operates With No Flow	
Possible Cause	- Trip points set too low
	- Vibration on pipe
Corrective Action	- Adjust trip points above 0 m/s
	- Relocate transducer
	- Use Neoprene rubber pad in transducer mounting
Relay Does Not Operate	
Possible Cause	- High trip point set below low trip point
	- Unit faulty
Corrective Action	- Adjust high trip point above low trip point
	- Return unit to factory
Signal Strength LED Not Illuminated, or Flickering slowly	
Possible Cause	- No flow
	- Insufficient suspended solids in fluid
	- Bad coupling of transducer
	- Incorrect transducer connections
Corrective Action	- Confirm flow
	- Inject air into pipeline
	- Check transducer mounting
	- Check transducer connections

Specifications

Measuring Range	:	0.3 to 2.0 m/s (1) 0.3 to 6.0 m/s (2)
Set Points	:	0 to 100% of Range
Timer Delays	:	0 to 60 seconds
Output	:	1 Relay - 1Amp SPDT
Transducer Cable	:	3 metre length
Temperature	:	Sensor -20 to 90°C Electronics -10 to 50°C
Electronics	:	IP65 Polycarbonate
Enclosure	:	120 x 120 x 55mm
Power Input	:	115/230V ac, 50Hz 24V dc +/-10%
Transducer	:	IP68 St/Steel 81 x 23 x 21mm
Indication LED's	:	10 LED bar graph Range selection Hi and Lo Alarm Signal Strength
Failsafe Mode	:	Selectable
Pipe sizes	:	25mm to 3000mm
Weight	:	0.85kg